



## **BUILD IN APPLIANCES**

FOR USE WITH PROPANE GAS

### **MODELS**

**S~OH7000Z - TRIPLEX**

**S~OH7100Z – TRIPLEX DUAL FUEL**



## **USER AND INSTALLATION INSTRUCTIONS**

PLEASE READ THOROUGHLY AND KEEP FOR FUTURE

## **FOR USE IN AUSTRALIA**

THETFORD AUSTRALIA PTY LTD  
41 LARA WAY CAMPBELLFIELD VIC  
TEL: 03 9358 0700 FAX: 03 9357 7060

**TRIPLEX (Euro Trim)**

**Side Batten (Optional)**  
 15x40x330mm  
 Fitted both sides

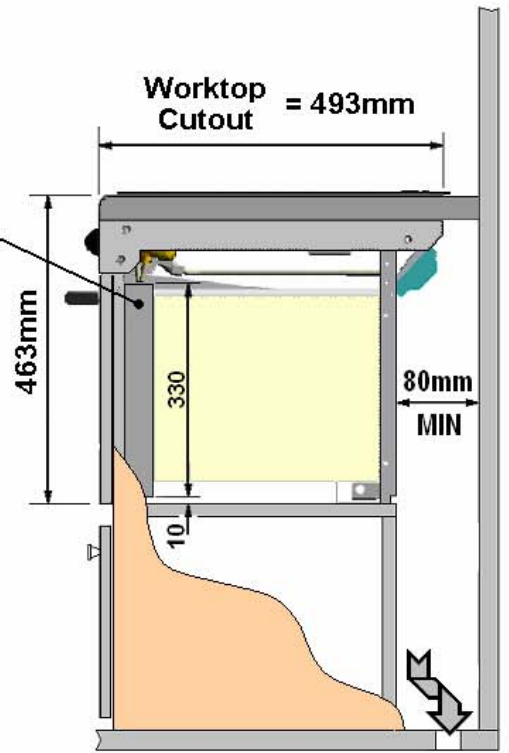
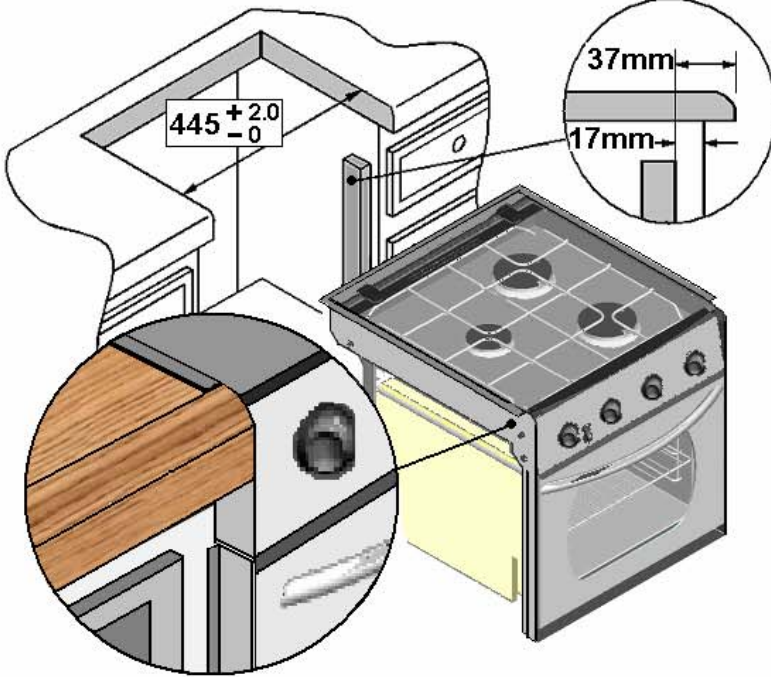

**TRIPLEX (Australian Trims)**

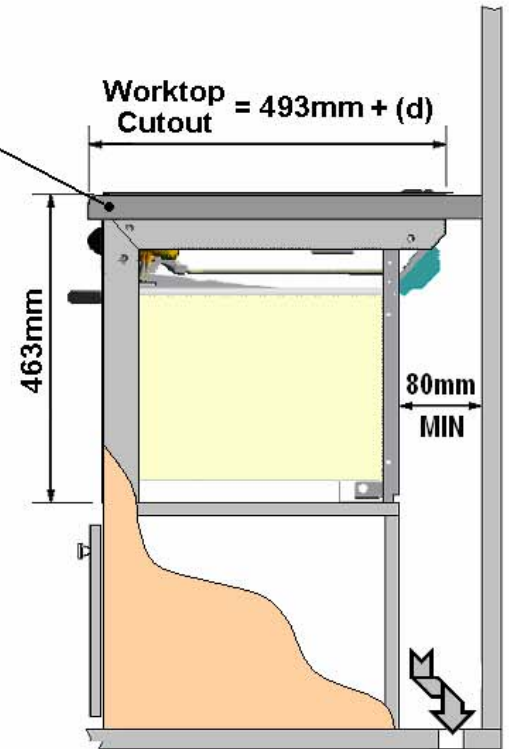
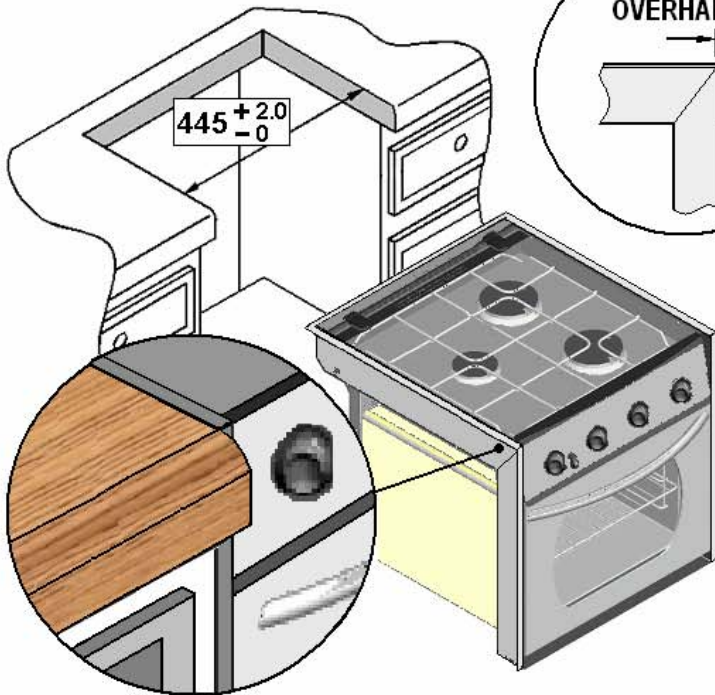

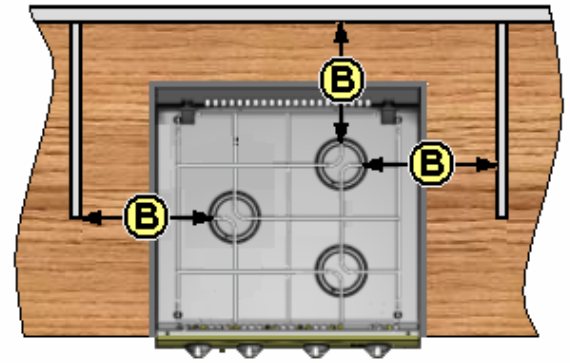
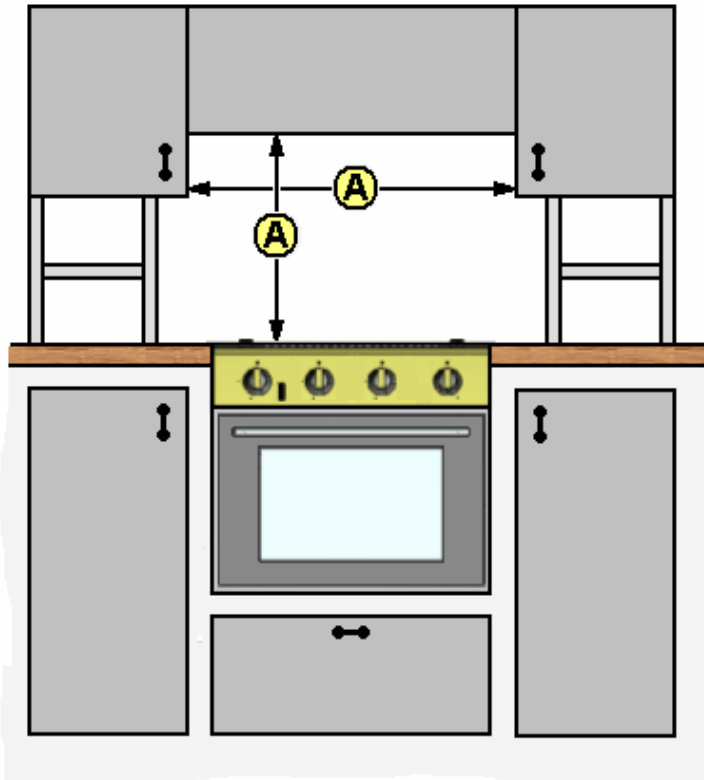

**A** = 500mm

**B** = 200mm

## WIRING DIAGRAM

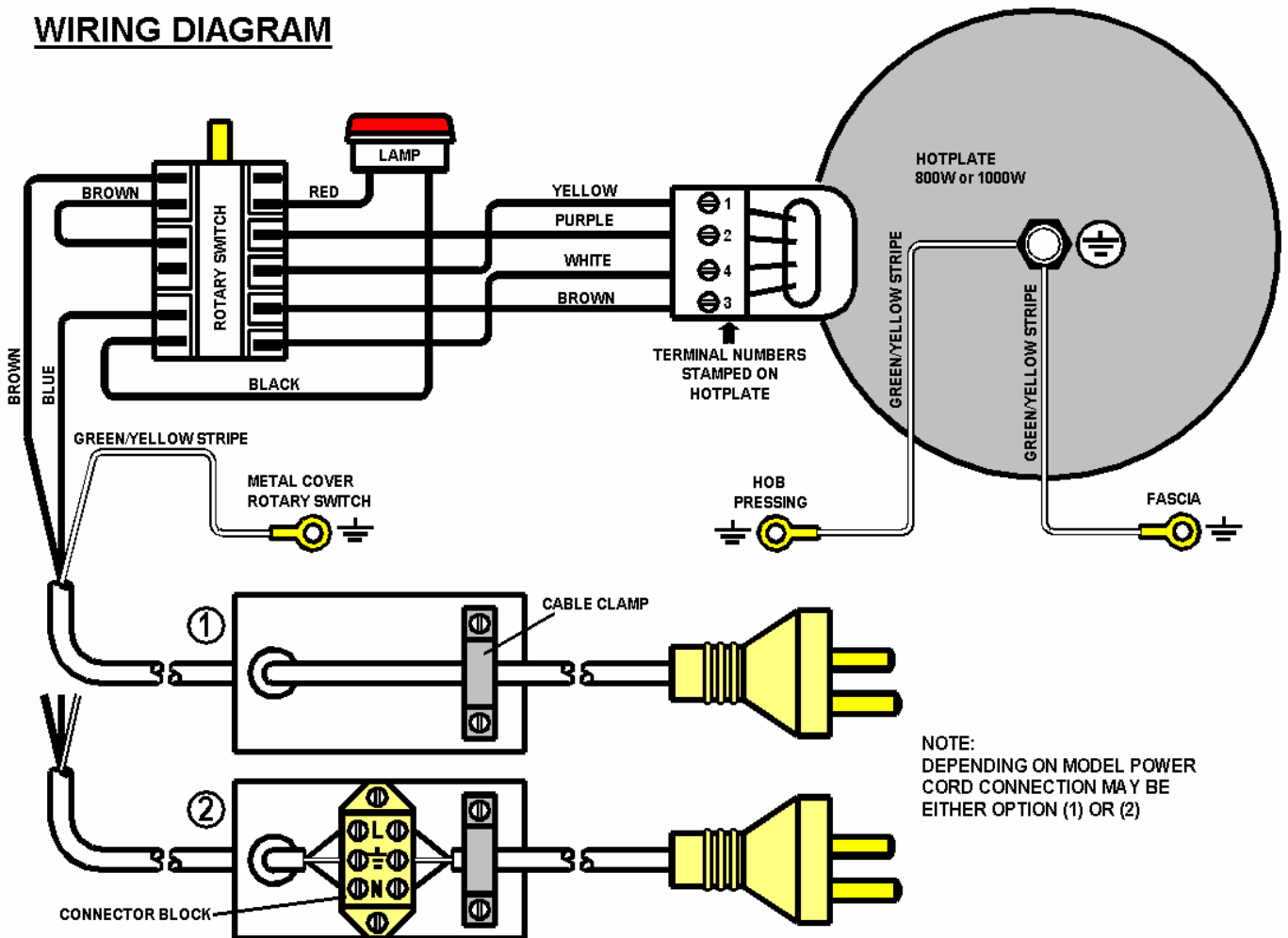

## SPECIFICATION

	TRIPLEX S-OH70000Z	TRIPLEX S-OH70000Z	TRIPLEX S-OH70000Z	TRIPLEX S-OH70000Z	TRIPLEX S-OH71000Z
<b>Model Range</b>	S-OH70000Z	S-OH70000Z	S-OH70000Z	S-OH70000Z	S-OH71000Z
<b>External Dimensions, mm</b> (HxWxD)	468 x 456 x 500mm	468 x 456 x 500mm	468 x 456 x 500mm	468 x 456 x 500mm	468 x 456 x 500mm
<b>Oven Capacity, litres</b>	36	36	36	36	36
<b>No. of tray positions</b>	Grill 2, Oven 4	Grill 2, Oven 4	Grill 2, Oven 4	Grill 2, Oven 4	Grill 2, Oven 4
<b>Heat input</b>					
Total heat input	29.4MJ/h	27.1MJ/h	25.5MJ/h	32.3MJ/h	23.3MJ/h 800W Elec ( <b>Note 1</b> )
Hotplate Burners (LPG)	3 x 6.1MJ/h	2 x 6.1MJ/h AUX 1 x 3.8MJ/h	2 x 5.3MJ/h AUX 1 x 3.8MJ/h	2 x 6.1MJ/h 1 x 9.0MJ/h	2 x 6.1MJ/h
Electric Hotplate (220V - 240V ~ 50Hz)	N/A	N/A	N/A	N/A	1 x 1000W Max
Grill burner heat input	5.3MJ/h	5.3MJ/h	5.3MJ/h	5.3MJ/h	5.3MJ/h
Oven burner heat input	5.8MJ/h	5.8MJ/h	5.8MJ/h	5.8MJ/h	5.8MJ/h
<b>Injector size, mm</b>					
Hotplate Burners	Sabaf 0.67	Sabaf 2x0.67, 1x0.53	Sabaf 2x0.62, 1x0.53	Sabaf 2x0.67, 1x0.81	Sabaf 2x0.67
Grill burner	Sabaf 0.62	Sabaf 0.62	Sabaf 0.62	Sabaf 0.62	Sabaf 0.62
Oven burner	Sabaf 0.65	Sabaf 0.65	Sabaf 0.65	Sabaf 0.65	Sabaf 0.65
<b>Bypass size, mm</b>					
Hotplate Controls	Sabaf 0.34	Sabaf 0.34	Sabaf 0.34	Sabaf 0.34	Sabaf 0.34
Grill control	N/A	N/A	N/A	N/A	N/A
Oven control	Sabaf 0.35	Sabaf 0.35	Sabaf 0.35	Sabaf 0.35	Sabaf 0.35
<b>Spark ignition</b> (where fitted)	12V	12V	12V	12V	12V
<b>Weight (Kg)</b>	21.5Kg	21.5Kg	21.5Kg	21.5Kg	23.1Kg

**Note 1:- Available with alternative 1000W Electric Hotplate**

**GAS: PROPANE only @ 2.75kpa**

### IMPORTANT

- THIS APPLIANCE IS SUITABLE FOR USE WITH PROPANE AND SHOULD NOT BE USED ON ANY OTHER GAS.
- USE ONLY THE GAS PRESSURES SPECIFIED ABOVE
- THIS APPLIANCE MUST BE EARTHED.

## **INTRODUCTION**

---

In your own interest of safety, gas appliances should be installed by competent persons. Failure to install the appliance correctly could invalidate any warranty or liability claims. This appliance shall be installed in accordance with the manufacturers installation instructions, local gas fitting regulations, municipal building codes, AG5601 and any other relevant statutory regulations.

### **Data label.**

The data label is located on the right hand side front of the oven compartment, behind the oven door. A duplicate data label is supplied to adhere to an accessible area next to the appliance. Ensure that the gas supply is Propane. This appliance is designed for use with Propane gas and should not be converted for use with any other gas.

### **Provision of Ventilation**

The use of a gas cooking appliance results in a production of heat and moisture in a room in which it is installed. Ensure that the kitchen is well ventilated and in accordance with AG5601 Installation Code. In general, the appliance should have adequate ventilation for complete combustion of gas, proper flueing and to maintain temperature of immediate surroundings within safe limits.

### **Location**

This appliance maybe installed in a kitchen/kitchen diner but NOT in a room containing a bath or a shower. LP gas appliances must not be fitted below ground level. e.g. in a basement.

Choose a location free of draughts, open doors and clear of combustible materials and other fire hazards. The location should ensure convenience of operation and service. Any adjoining wall surface situated within 200mm from the edge of any hob burner must be made from a suitable non-combustible material for a height of 150mm for the entire length of the hotplate.

### **IMPORTANT**

- This appliance must be installed into an aperture, sealed off at either side in order to prevent draughts from adjoining cupboards/vents. Ensure that air vents and gas escape holes are kept clear, holes for cables and pipes must be sized to minimize air leakage between compartments.
- Under no circumstances should the ventilation hole exceed 3850mm<sup>2</sup> or other low level ventilation be located in the compartment, including vents in kickboards. Low level vents in adjacent compartments are permitted.

## OPERATION

---

### WARNING

- The appliance is not intended for use by young children or infirm persons, without supervision
- Young children should be supervised to ensure they do not play with the appliance.
- Glass lids may shatter when heated. Turn off all burners before shutting the lid
- Spillage on the surface of the lid should be removed before opening the lid.

### Burner operation

The burners on this appliance have fixed aeration and no adjustment is required. The burners should flame as follows:-

Propane - The flames should burn quietly with a blue/green colour with no sign of yellow tips.

### IMPORTANT

- Although each burner will support pans from 10 to 22cm, care should be taken not to overload the appliance as reduced performance may result.
- When using small pans the flames should not spread beyond the base of the pan as this will reduce the efficiency of the burner.
- Avoid old or misshapen pans as these may cause instability.
- The lid must be opened fully prior to using the hotplate burners.

### Using the Hob Burners

- (1) Ensure gas supply is connected and turned on.
- (2) Push in the control knob and turn anticlockwise to full rate – large flame (🔥).
- (3) Continue depressing the knob whilst holding a lighted match to the burner.
- (4) After the burner is lit continue depressing the knob for approximately 10 - 15 seconds.
- (5) Release knob and turn to required heat setting.
- (6) If burner has not lit within 15 seconds, release knob and wait at least 1 minute before repeating operations (2) to (5).
- (7) To turn off, rotate the control knob until the line on the knob is aligned with dot on the control panel.

For models fitted with Spark Ignition the procedure is similar except that the burner is ignited by depressing the ignition button located on the fascia.

Always make sure the control knob is in the off position when you have finished using the hotplate burners.

## **OPERATION**

---

### **WARNING**

- **Glass lids may shatter when heated. Turn off the hotplate and allow it to cool before closing the glass lid.**
- **Remove all spillage from the surface of the glass lid before opening.**

### **Using the Electric Hotplate**

Ensure the electricity is switched on.

The hotplate control is numbered from 1 to 6. To turn it on, rotate the knob either clockwise or anti-clockwise to the required position. Position 1 is the coolest setting. To turn the hotplate off, rotate the knob until the line or pointer on the knob lines up with the zero on the control panel. The hotplate is a sealed construction and transfers heat through conduction. For maximum efficiency a correctly sized pan with a flat heavy gauge base should be used. Pan size should be the same or slightly larger (up to 1" / 2.5 cm oversize).

Before using your hotplate for the first time, we recommend that you prime and then season it.

#### To prime the Hotplate

Switch on the hotplate for a short period, without a pan, to harden and burn off the coating. Use a medium to high setting for 3 – 5 minutes. A non toxic smoke may occur during this process. Allow it to cool, then season.

#### To season the Hotplate

First heat the hotplate for 30 seconds on a medium setting, then switch off. Pour a minimal amount of unsalted vegetable oil onto a clean dry cloth or paper towel, and apply a thin coat of oil to the hotplate surface. Wipe off any excess oil, then heat the hotplate on a medium setting for 1 minute. Occasional seasoning will help to maintain the Hotplate's appearance.

### **IMPORTANT**

- Depending on specification, your appliance may be fitted with a glass lid shut-off system, which cuts off the power to all hotplate burners (gas and electric) if the lid is closed.
- Ensure the glass lid is in the open and upright position before turning on the hotplate burners.
- Not all models are fitted with the shut-off system.

## OPERATION

---

### IMPORTANT

- The grill **MUST** only be used with the door open.
- When grilling the oven shelf should be located on the middle runner.
- The heat deflector below the fascia should be pulled out prior to lighting the grill. Never adjust the heat deflector position without using hand

### Using the Grill

1. Ensure gas cylinder/supply is connected and turned on. In the event of a gas smell turn off at gas cylinder/mains and contact supplier.
2. Note: The grill is fitted with a safety shut off device and will only operate with the door open.
3. To light: Open door, push in the control knob and turn clockwise to full rate, large flame (🔥). Hold a lighted match or taper to the burner and push the control knob in and hold. The burner should ignite and the control knob should be held in for 10 -15 seconds before release. If the burner goes out, repeat procedure holding control knob for slightly longer.
4. For models fitted with Spark Ignition the procedure is similar except that the burner can be ignited by depressing the ignition button, which is located on the fascia. Ignition must be carried out with the door open, and if the burner has not lit within 15 seconds the control knob should be released and the grill left for at least 1 minute before a further attempt to ignite the burner.
5. On first use of the grill, it should be heated for about 20 minutes to eliminate any residual factory lubricants that might impart unpleasant smells to the food being cooked. A non-toxic smoke may occur when using for the first time so open any windows and turn on mechanical ventilators to help remove the smoke.
6. Although the grill does heat up quickly, it is recommended that a few minutes preheat be allowed.
7. Flame Failure Device (FFD): the grill burner is fitted with a flame sensing probe, which will automatically cut off the gas supply in the event of the flame going out. In the event of the burner flames being accidentally extinguished, turn off the burner control and do not attempt to re-ignite the burner for at least one minute.
8. It is normal for the flames on this burner to develop yellow tips as it heats up.
9. A reversible grill pan trivet enables the correct grilling height to be achieved.
10. To turn off: turn the control knob until the line on the control knob is aligned with the dot on the control panel. Always make sure the control knob is in the off position when you have finished grilling.

### IMPORTANT

- The control tap on this appliance operates both the Grill and Oven burners. To ensure safe operation it is not possible to operate both burners at the same time.
- The pan supplied with the appliance is multi functional, for use either whilst grilling or when using the oven. The handle design allows removal or insertion whilst the pan is in use. Always remove the handle when the pan is in use.



## OPERATION

### WARNING

When cooking always ensure young children are kept away.

### Using the Oven

1. Ensure gas cylinder/supply is connected and turned on. In the event of a gas smell turn off at gas cylinder/mains and contact supplier.
2. To light: Open door, push in the control knob and turn to full rate (Gas Mark 9, 240°C). Hold a lighted match or taper to the burner and push the control knob in and hold. The burner should ignite and the control knob should be held in for 10 -15 seconds before release. If the burner goes out, repeat procedure holding control knob for slightly longer.
3. For models fitted with Spark Ignition the procedure is similar except that the burner can be ignited by depressing the ignition button located on the fascia. Ignition must be carried out with the door open, and if the burner has not lit within 15 seconds the control knob should be released and the oven left for at least 1 minute before a further attempt to ignite the burner.
4. Place the oven shelf in the required position and close the door.
5. Although the oven does heat up quickly, it is recommended that a 10 minutes preheat be allowed. The oven should be up to full temperature in about 15-20mins.
6. To turn off: turn the control knob until the line on the control knob is aligned with the dot on the control panel.
7. Shelf: The shelf has been designed to allow good circulation at the rear of the oven. A raised bar at the rear of the shelf prevents trays or dishes making contact with the back of the oven. To remove a shelf, pull forward until it stops, raise at front and remove.

### Oven Temperature Control

The temperature in the oven is controlled by a thermostatic gas tap and is variable over the range 130°C to 240°C. Approximate temperatures for the settings on the control knob are shown in the table below. The temperatures indicated refer to the centre of the oven and at any particular setting the oven will be hotter at the top and cooler towards the base.

The variation between top and centre, and centre to bottom is approximately equivalent to one gas mark. Good use can be made of the temperature variation in several dishes requiring different temperatures may be cooked at the same time. In this way maximum benefit can be obtained from the gas used to heat the oven.

Care should be taken not to overload the oven, allow adequate spacing to ensure free circulation of heat. When roasting with aluminium foil ensure the foil does not impair circulation of heat or block anythe oven flue outlet.

Gas Mark	Temperature (Centre of Oven)			Dish
¼ - ½	265-275°F	130-135°C	Very cool	Meringues
1	285	140	Cool	Stewed fruit
2	300	150	Cool	Rich fruit cake, rice pudding
3	330	165	Warm	Baked custard, shortbread fingers
4	355	180	Moderate	Victoria sandwich
5	385	195	Fairly hot	Whisked sponges, ginger nuts
6	410	210	Hot	Short crust pastry
7	430	220	Hot	Bread, scones, flaky pastry
8	445	230	Very hot	Puff pastry
9	465	240	Very hot	Quick browning

## **OPERATION**

---

### **Do's and Don'ts**

- DO Read the user instructions carefully before first use of the appliance.
- DO Allow the oven to heat before using for the first time, in order to expel any smells before the introduction of food.
- DO Clean the appliance regularly.
- DO Remove spills as soon as they occur.
- DO Always use oven gloves when removing food shelves and trays from the oven.
- DO Check that controls are in the off position when finished.
  
- DO NOT Allow children near the cooker when in use. Turn pan handles away from the front so that they cannot be caught accidentally.
- DO NOT Allow fats or oils to build up in the oven trays or base.
- DO NOT Use abrasive cleaners or powders that will scratch the surfaces of the appliance.
- DO NOT Under any circumstances use the oven as a space heater.
- DO NOT Put heavy objects onto open grill and oven doors.

### **LEAKS**

If a smell of gas becomes apparent, the supply should be turned off at the cylinder **IMMEDIATELY**. Extinguish naked lights including cigarettes and pipes. Do not operate electrical switches. Open all doors and windows to disperse any gas escape. Butane/Propane gas is heavier than air; any gas escaping will therefore collect at low level. The strong unpleasant smell of gas will enable the general area of the leak to be detected. Check that the gas is not escaping from an unlit appliance. Never check for leaks with a naked flame; leak investigation should be carried out using a leak detector spray.

### **Abnormal Operation**

Any of the following are considered to be abnormal operation and may require servicing.

- Yellow tipping of burner flame.
- Sooting of cooking utensils.
- Burners not igniting properly.
- Burners failing to remain alight
- Burners extinguished by cupboard doors.
- Gas valves that are difficult to turn

•

### **WARNINGS**

- **DO NOT** store or use gasoline or other flammable vapours, liquids or items in the vicinity of this or any other appliance.
- **DO NOT** spray aerosols in the vicinity of this appliance while it is in operation.
- **NEVER** use the appliance as a space heater, either in marine craft, caravans or motor homes.
- **NEVER** check for leaks with an open flame

## **INSTALLATION**

---

### **Regulations and Standards**

In your own interest of safety, gas appliances should be installed by competent persons. Failure to install the appliance correctly could invalidate any warranty or liability claims. This appliance shall be installed in accordance with the manufacturers installation instructions, local gas fitting regulations, municipal building codes, AG5601 and any other relevant statutory regulations.

### **Data label.**

The data label is located on the right hand side front of the oven compartment, behind the oven door. A duplicate data label is supplied to adhere to an accessible area next to the appliance. Ensure that the gas supply is Propane. This appliance is designed for use with Propane gas and should not be converted for use with any other gas.

### **Ventilation**

This appliance is suitable for installation into Holiday Homes, Touring Caravans and Boats. In all cases the national standards with regard to ventilation for the particular vehicle into which the appliance is to be installed must be adhered to.

The appliance **MUST** have a gas escape hole (min size Ø25mm; max Ø50mm; or shaped hole of equivalent area) in the floor, directly beneath the appliance and positioned at the rear as shown in the attached diagrams. The hole **MUST** vent to the outside and should be baffled to prevent direct draught to the appliance.

### **Location of Appliance**

This appliance maybe installed in a kitchen/kitchen diner but NOT in a room containing a bath or a shower. LP gas appliances must not be fitted below ground level. e.g. in a basement.

### **Position**

**CAUTION: DO NOT LIFT APPLIANCE USING THE DOOR HANDLES**

A cutout should be prepared as shown in the enclosed diagrams. The cutout **MUST** comply with the dimensions shown and include the low ventilation indicated.

A horizontal distance of 200mm must exist between the edge of the burner and combustible material unless protected by a layer of non-combustible material. Unless the appliance is fitted with a glass lid a non-combustible heat shield (splash back) must be fitted onto the rear wall directly behind the appliance.

This appliance must be positioned free from draughts, which may affect the combustion, and in a manner that will prevent the accumulation of unburnt gas. When in use ensure that air vents are not inadvertently blocked or shut off. Ensure all combustible materials such as curtains and shelves are well clear of the appliance.

The performance of this appliance meets the requirements of the Australian Standard for Domestic Cooking Appliances. We recommend the installation follows the minimum dimensions shown in this manual as any deviation could result in excessive temperature rise. If minimum dimensions must be reduced, due to design constraints, a temperature rise test of all furniture fitted around the unit **MUST** be performed. The design is deemed permissible providing the results of this test comply with all standards in force and the requirements detailed within the furniture manufacturer's material specification. Where minimum dimensions are reduced we recommend protecting with non combustible material.

## INSTALLATION

### IMPORTANT

- This appliance must be installed into an aperture, sealed off at either side in order to prevent draughts from adjoining cupboards/vents. Ensure that air vents and gas escape holes are kept clear, holes for cables and pipes must be sized to minimize air leakage between compartments.
- Under no circumstances should the ventilation hole exceed the maximum size specified. Low level vents in adjacent compartments are permitted.
- Any cupboards beneath the appliance **MUST** be sealed to prevent a gas escape entering the living area.

### Fixing

The appliance can be front or side fixed, holes are provided for either installation method. Fixing screw positions are located as follows.

Appliance	Front Fixed Appliance	Side Fixed Appliance
<b>S~OH7000Z</b> & <b>S~OH7100Z</b>	2 <b>front</b> fix holes each side of Oven opening 2 fix holes each hotplate side trim	2 <b>side</b> fix holes each side of Oven opening 2 fix holes each hotplate side trim

### Connection

A ¼ BSP female connection is provided for gas inlet, on the rear of the appliance. It is recommended that the appliance be connected by copper tubing, a rubber or hose connection must not be used. After connection the appliance must be tested for soundness.

This appliance is suitable for use on –

**Propane Gas Only      2.75 Kpa.**

It is important that the regulator should be set to the correct pressure for the type of gas being used. Excessive pressure must not be permitted.

If the flame on either the top burners or the grill show a tendency to lift, it is probable that the line pressure is too great. Should there be excessive yellow tips (resulting in sooting) then it is probable that the line pressure is too low and, in either case, the burners should not be used until the line pressure has been checked.

This appliance is fitted with the following injectors:-

<b>HOB</b>	<b>0.81mm 9.0 MJ/h</b>
	<b>0.67mm 6.1 MJ/h</b>
	<b>0.62mm 5.3 MJ/h</b>
	<b>0.53mm 3.8 MJ/h</b>
<b>GRILL</b>	<b>0.62mm 5.3 MJ/h</b>
<b>OVEN</b>	<b>0.65mm 5.8 MJ/h</b>

The burners on this appliance have fixed aeration and no adjustment is necessary.

## **INSTALLATION**

---

### **Connection - Electrical**

The appliance is supplied with a power cord and plug which must be connected to a double pole switched mains supply, with 3mm minimum contact separation at all poles.

Any excess power cord **MUST** be routed away from the appliance and not come into contact with the appliance or hang loose into a lower compartment.

When satisfied with the appliance, please instruct the user on the correct method of operation. If the appliance fails to operate correctly after all checks have been made, refer to the authorised service provider in your area.

### **IMPORTANT**

- This appliance must be earthed
- If the supply cord is damaged, it must be replaced by the manufacturer, its service agent or a similarly qualified person in order to avoid a hazard
- After installation the appliance **MUST** be tested for soundness
- Test ALL burners on high and low flame for flame stability.
- The gas supply input pressure **MUST** not rise or fall significantly from nominal when ALL appliances connected to the supply are operated simultaneously.

## **MAINTENANCE & SERVICING**

---

### **IMPORTANT**

- All servicing must be carried out by an approved competent person.
- After each service the appliance must be checked for gas soundness

This appliance needs little maintenance other than cleaning. All parts should be cleaned using warm soapy water. Do not use abrasive cleaners, steel wool or cleansing powders. When cleaning the burner ring it is essential to ensure that the holes do not become blocked.

The control knobs are a push fit and can be removed for cleaning. They are interchangeable without affecting the sense of operation.

### **Who To Contact**

For service, please contact your authorised local Service Agent giving full details of the model, serial number and date of purchase.

### **Manufactured by:**

THETFORD Limited.  
Unit 19 Oakham Drive,  
Parkwood Industrial Estate,  
Rutland Road,  
Sheffield. S3 9QX. England.

### **Service Instructions**

#### **1. Disconnect from gas supply**

Lift and remove the bottom plinth to gain access, then disconnect the gas supply. If the appliance is Dual Fuel, disconnect/isolate the electric supply.

#### **2. Remove hob surface**

Disconnect from gas supply (1) and electric supply if Dual Fuel. Lift off the Panrest and remove the two screws securing each burner spreader. Remove front fascia by removing all push on control knobs and unscrew the two recessed fixed nuts and both fascia retaining screws. Carefully lift off the fascia and if spark ignition fitted remove the two spade connectors from the rear of the toggle switch. Remove the two central screws securing the pressing to the rear box section. Remove the two front retaining screws located each side and accessed through the outer slots on the angled front. Grasp the hob by the angled front face, carefully lift the hob surface from the front to allow the rear edge to unhook from the rear box section. Note:- On Dual Fuel appliances, remove the hotplate rear cover and disconnect the power leads. The hob surface should be put onto a suitable surface.

#### **3. Remove appliance from housing**

Disconnect from gas supply (1). Open the oven door and remove the 2 screws from each side trim - note the appliance can either be front or side fixed, see under **Fixing**, page 13. Open the glass lid and remove the 2 screws from each side trim. Carefully slide the appliance out one third and check for any possible snagging of wires or pipes. If the appliance is Dual Fuel, disconnect supply lead from rear terminal block. If OK, lift appliance out onto a suitable surface.

## **MAINTENANCE AND SERVICING**

---

### **4. Control replacement**

#### **Hob controls**

Disconnect from gas supply (1). Remove hob surface (2). Unscrew the corresponding pipe and thermocouple and remove from the control.

Open the oven door and unscrew the 2 screws holding the thermostat probe in position and push the probe back out through the hole in the rear of oven. Remove the retaining screws from on top and underneath the control. Disconnect the inlet pipe and two burner supply pipes. Remove the fittings off the old control and fit on the replacement.

#### **Oven and Grill control**

As above instructions but remove appliance from housing to gain access to the oven thermostat, grill and oven thermocouples.

### **5. Remove the grill burner**

Disconnect from gas supply (1). Remove appliance from housing (3). Remove hob surface (2). Remove the two screws retaining the heat deflector. Remove the insulation wrap and remove the three grill flue retaining screws – two beneath the fascia panel, one located on top rear of flue cover. Lift off the flue cover. Lever off starlock washers retaining the grill burner.

### **6. Spark Ignition (where fitted)**

Disconnect from gas supply (1). Remove appliance from housing (2).

**Grill burner** – At rear of appliance remove the screw from the bracket and spark ignition probe. Trace the electrode wire back to the generator and pull off the connector.

**Oven burner** - Trace the electrode wire up the back of the cooker to the generator and pull off the connector. Unscrew the fixing screw on the spark electrode inside the oven cavity, then carefully pull the electrode from inside the oven and remove.

**Piezo Spark Generator replacement** - Remove all electrode wires. Remove the lock nut and carefully remove from panel.

**12v Spark Generator replacement** - Located at the rear of appliance. Remove all electrode wires, unscrew the two retaining screws and lift off the unit.

### **7. Grill burner injector (No62)**

Disconnect from gas supply (1). Remove appliance from housing (2).

Release the locking screw on the injector holder, disengage the grill pipe from the control and remove the injector.

### **8. Oven burner injector (No65)**

Open the oven door and unscrew the burner retaining screw, slide the burner to the left and lift out. The injector is exposed to the right hand side of the cut out. Unscrew the injector.

### **9. Thermocouple replacement**

Disconnect from gas supply (1). Remove appliance from housing (2).

**Grill burner** - Unscrew the thermocouple from the control. Unscrew the nut at the burner.

**Oven burner** - Unscrew the thermocouple from the control. Inside the oven cavity, the thermocouple is found just above the burner on the rear wall. Unscrew the locknut and pull out the thermocouple from the rear of the appliance.

### **10. Removing Drop Down Oven Door**

Open the door and engage catch to hook on each hinge. Lift the door and pull out of front trim.